

ELECTRIC PALLET TRUCK RIDER PLATFORM - EPT-45-RP-KIT

APPROX WEIGHT: 19.33 lbs.
DOES NOT INCLUDE WEIGHT OF POWER OR PACKAGING!!!

*** ANY ADDITIONS, DELETIONS, OR OMISSIONS MUST BE CORRECTED ON THIS DRAWING AS THIS DRAWING WILL BE CONSIDERED ALL INCLUSIVE ***

ALL GRAPHICS PROVIDED ARE FOR REFERENCE ONLY. IF CERTAIN DIMENSIONS ARE CRITICAL PLEASE VERIFY THOSE DIMENSIONS WITH YOUR SALESPERSON

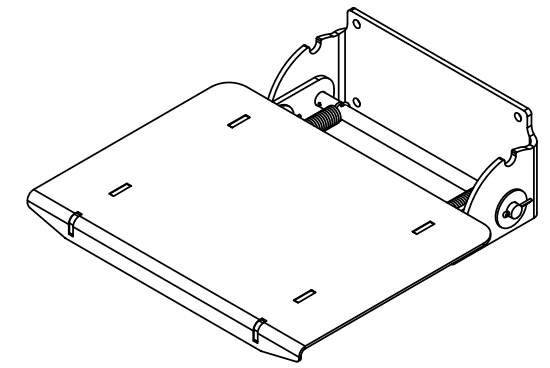
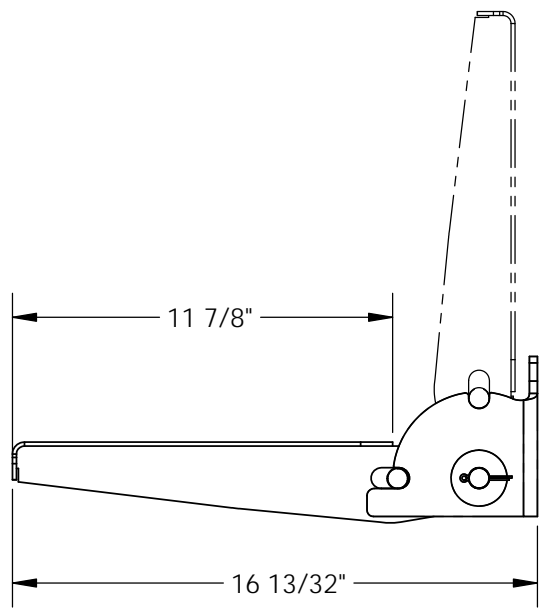
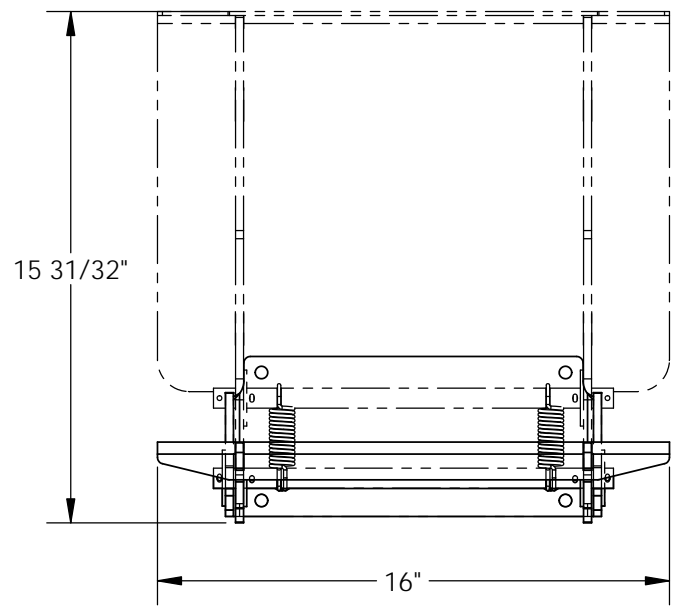

3-D VIEW
SCALE: 1:8

STANDARD FEATURES

- MODEL NUMBER IS EPT-45-RP-KIT
- OVERALL WIDTH IS 16"
- USABLE WIDTH IS 16"
- OVERALL LENGTH IS 16 13/32"
- USABLE LENGTH IS 11 7/8"
- OVERALL HEIGHT IS 15 31/32"
- MAX. CAPACITY IS 250 LBS

SPECIAL FEATURES

NONE

DIMENSION TOLERANCE ± 1/4"

A P P R O V A L	I, THE UNDERSIGNED, AGREE THAT THE PRODUCT AS REPRESENTED SATISFIES DESIGN AND DIMENSION REQUIREMENTS. I ALSO ACKNOWLEDGE MY DUTY TO CONFIRM PRODUCT AND INSTALLATION COMPLIANCE WITH ALL APPLICABLE FEDERAL, STATE AND LOCAL REGULATIONS AND STANDARDS.	
	ALL SPECIAL UNITS ARE NON-RETURNABLE [] As drawn [] As marked	
Signed: _____		Date: _____
LEAD TIME WILL START UPON RECEIPT OF SIGNED APPROVAL DRAWING		

FOR INTERNAL USE ONLY PROJECT SIGN OFF	
SALES	
ENG.	
FAB.	
POWER	

DISTRIBUTOR'S NAME:		P.O.#
VESTIL MANUFACTURING		X
DRAWN BY:	DATE:	W.O.#
W.BURKHART	06/02/15	X
REFERENCE:	SCALE:	SALES:
X	1:6	X
QUOTED LEAD TIME:	QUOTE #	FILE NAME:
X	X	15-007-144